

## Tubular Control Valve

## Bulletin 814

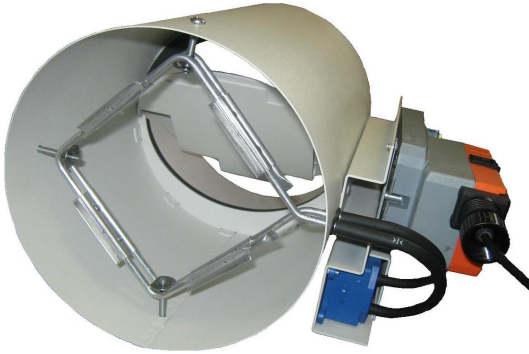

WTV with Air Flow Station and Transmitter

### Product Design

The 814 Tubular control valve is designed for spaces requiring very close and repeatable environmental conditions. In addition, the performance is accurate and linear whether the valve is opening or closing.

The control valve is based on a formed blade with supplementary airfoil profiles added to the blade surface, minimizing dead spaces downstream of the blade. The airfoil blade modulates within an internal low loss orifice. This relationship between the modified blades and the orifice results in linear performance throughout the normal control range as well as no measurable hysteresis.

Additionally, the pressure drop and noise levels are very low – below other control valves used for critical air flow. The low pressure drop permits damper selection within ASHRAE 90.1 guidelines.

### Applications

- Laboratory Supply and Exhaust
- Pharmaceutical Manufacturing
- Clean Spaces
- Containment Areas

### Benefits

- Wide Performance Range
- Electronic or Pneumatic Actuator
- Proven Technology
- Ease of Installation
- Cost Effective

### Control Components

The control valve is available with a wide range of factory-mounted controls.

For systems utilizing instrument air, pneumatic actuators are used for both CV and VAV applications. Transducer and transmitters can also be factory furnished and piped. Transmitters and transducers will utilize normal analog outputs and inputs.

Programmable Electronic actuators can be used for fast and repeatable load management. When used with a local controller, several actuators can maintain a constant space pressure with varying supply and exhaust flow rates. Special programs are available, including volumetric offset with pressure override and pressure independence.

## Aerodynamic Performance

Nominal Size	Volumetric Flow Rate Range		Velocity Range	
	CFM	m <sup>3</sup> /hr	ft/min	m/s
4	35-180	58-294	400-2000	2.03-10.16
6	80-400	130-661	400-2000	2.03-10.16
8	140-700	230-1175	400-2000	2.03-10.16
10	220-1100	439-2240	400-2000	2.03-10.16
12	315-1580	526-2681	400-2000	2.03-10.16
14	428-2140	713-3635	400-2000	2.03-10.16
16	560-2800	936-4774	400-2000	2.03-10.16
18	708-3540	1181-6022	400-2000	2.03-10.16

## Dimensions

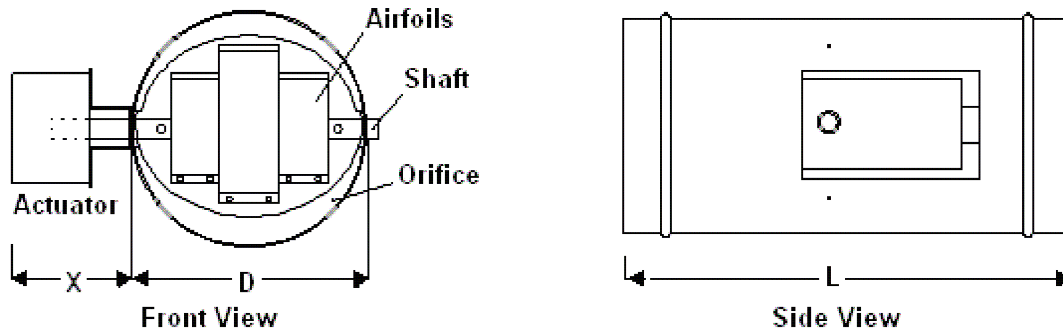

D = Nominal Size – 1/8"

L = 15" for Nominal Size 4 – 10; 20" for Nominal Size 12-16

Contact Factory for Specific dimensional drawings

## Miscellaneous

**Valve Construction** The tubular valve is available in powder-coated galvanized steel, aluminum, or stainless steel. The axial seam is fully welded. Bearings are metal backed Teflon composite.

**Actuators** Pneumatic – 20 PSI main air with 8-13 PSI modulating range  
 Electronic – 24V ac/dc input 0-10V, 4-20mA, Integrated volume and pressure sensor  
 Optional Lon Works integration.

**Insulation** Optional for supply valves. Closed cell Smoke and Flame spread rating 25/50

 Phone: (856)-461-7500  
**AIR DISTRIBUTION PRODUCTS DIVISION**  
 26 D Deacon's Alley • Moorestown • NJ 08057

YOUR LOCAL REPRESENTATIVE

The Waddell 814 Tubular Valve and 816 Rectangular Electronic Control Valve was designed to offer linear and hysteresis free performance together with a very low pressure drop. These characteristics have served our clients well with our pneumatic damper for over 20 years and are offered again in our 814 tubular valve and 816 series valve.

Additionally, the low pressure drop of both products complies with the energy saving requirements of ASHRAE 90.1 2007.

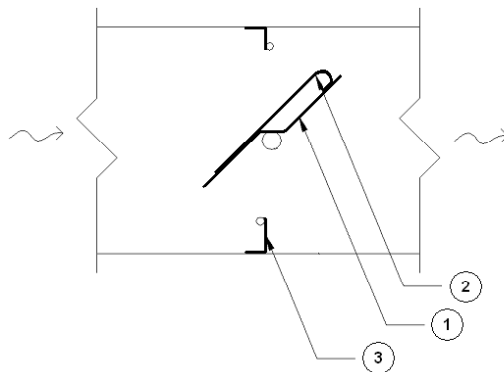

The special performance of the valve is a result of a unique combination of time proven design fundamentals.

1. The underlying blade assures a low initial pressure drop.
2. The addition of the air foil shapes to the formed blade minimizes downstream vortices during modulation and contributes to the valve linearity and minimal hysteresis.
3. The location of the modulating assembly within an internal orifice enables the valve to offer linearity and minimal hysteresis from wide-open position through to a closed off position.

Assembled View of Tubular Valve with Air Flow Station

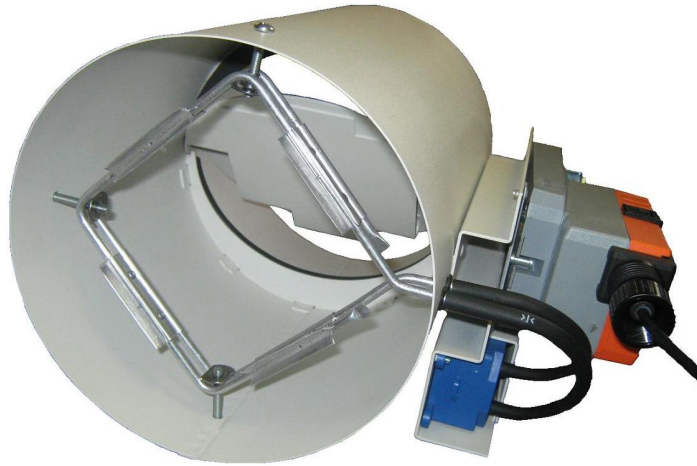

A cross-sectional view of the valve showing the air flow through the valve at three points of modulation is illustrated below.

Full Open

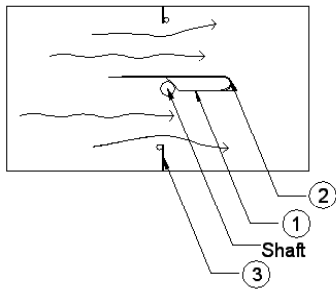

Modulating

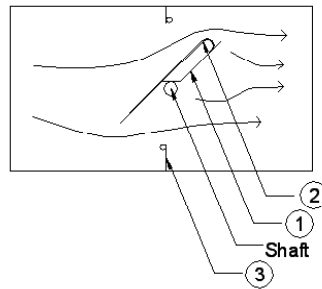

Closed

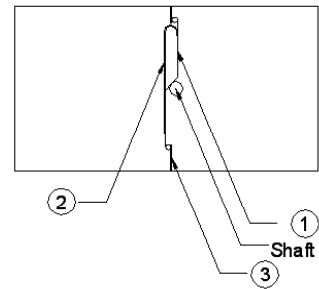

Isometric View of Internal Components

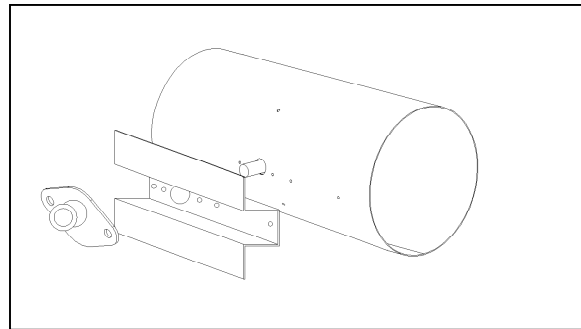
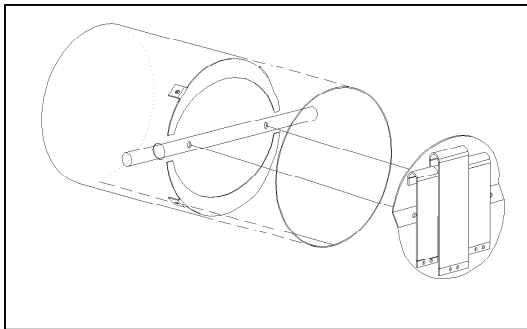

Phone: (856)-461-7500

**AIR DISTRIBUTION PRODUCTS DIVISION**  
26 D Deacon's Alley • Moorestown • NJ 08057

**YOUR LOCAL REPRESENTATIVE**

## APPLICATION GUIDELINES

### TUBULAR CONTROL VALVE – Model 814

#### SELECTION

- The intent of the Waddell Tubular Control Valve is to accurately and repetitively modulate the air flow or pressure to or from a space. The valve should be sized to operate in a partially closed position so it can modulate regardless of the upstream pressure.

**VOLUMETRIC FLOW (CFM) AT VARIOUS FACE VELOCITIES  
WIDE OPEN TUBULAR VALVE**

SIZE	AREA	400	600	800	1000	1200	1400	1600	1800	2000
in	ft <sup>2</sup>	ft/min	ft/min	ft/min	ft/min	ft/min	ft/min	ft/min	ft/min	ft/min
4	0.09	36	54	72	90	108	126	144	162	180
6	0.20	80	120	160	200	240	280	320	360	400
8	0.35	140	210	280	350	420	490	560	630	700
10	0.55	220	330	440	550	660	770	880	990	1100
12	0.79	316	474	632	790	948	1106	1264	1422	1580
14	1.07	428	642	856	1070	1284	1498	1712	1926	2140
16	1.40	560	840	1120	1400	1680	1960	2240	2520	2800
18	1.77	708	1062	1416	1770	2124	2478	2832	3186	3540

**VOLUMETRIC FLOW (CMH) AT VARIOUS FACE VELOCITIES  
WIDE OPEN TUBULAR VALVE**

SIZE	AREA	2.0	3.0	4.1	5.1	6.1	7.1	8.1	9.1	10.2
mm	m <sup>2</sup>	m/s	m/s	m/s	m/s	m/s	m/s	m/s	m/s	m/s
102	0.008	58	86	118	147	176	204	233	262	294
152	0.018	130	194	266	330	395	460	525	590	661
203	0.032	230	346	472	588	703	818	933	1048	1175
254	0.051	367	551	753	936	1120	1304	1487	1671	1873
305	0.073	526	805	1074	1342	1611	1879	2148	2416	2684
356	0.099	713	1069	1461	1818	2174	2530	2887	3243	3635
406	0.130	936	1404	1919	2387	2855	3323	3791	4259	4774
457	0.164	1181	1771	2421	3011	3601	4192	4782	5373	6022

#### WIDE OPEN PRESSURE DROP

- The minimum pressure drop in the field can be estimated from the adjacent curve. The low wide-open pressure loss (0.29 in. ~ 72.5 Pa at 1500 ft/min ~ 7.62 m/s) complies with the proposed 0.5" maximum pressure loss guidelines in ASHRAE 90.1 for energy savings.
- The second curve illustrates the linearity and the lack of measurable hysteresis during modulation. This is the result of careful design of the internal components and assures repetitive space conditions

